

30cm Domino Fryer

Code EMJFR30SX Stainless Steel



THE euro MILAN DOMINO DEEP FRYER

Will allow you to create your own home made Deep fried Calamari, spring rolls or fish and chips, with a Domino Deep Fryer installed in your kitchen, or your Alfresco area the options are endless. The Domino Deep Fryer is equipped with On / Off indicator light and automatic temperature cut out.

FEATURES

- Stainless Steel
- Maximum / Minimum cooking container
 - 2.0-2.5 litre capacity
- Removable Stainless Steel oil container that can be stored in the refrigerator
- Oil container lid
- Thermostatically controlled Temperature
- Variable 0 – 200 degrees temperature control
- Front knob control operation
- On / Off indicator light
- Automatic safety temperature cut out
- Movable heating element for easy cleaning
- Made in Italy

AUTOMATIC SAFETY TEMPERATURE CUT OUT

This Fryer is provided with a cut-off device which intervenes if the oil temperature exceeds the safety limit. This device stops the fryer from functioning. For the fryer to start functioning again, you must wait until the oil temperature drops, then release the cut-off switch manually to start the appliance again.

PRODUCT DIMENSIONS

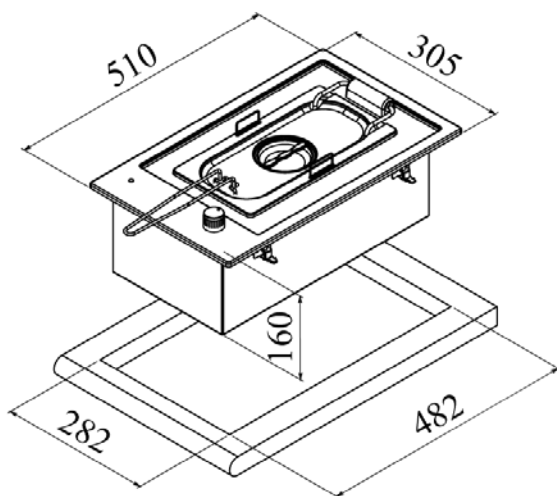

ELECTRICAL REQUIREMENTS

10 amp dedicated circuit from cooktop to main switchboard.

VOLTAGE: 220V-240V

FREQUENCY: 50HZ

TOTAL RATED LOAD: 2300W

WEIGHT

8.5kg Gross

INSTALLATION:

Please refer qualified installer to our product instruction manual.

